

Wheel Refacer 250

TABER[®]
INDUSTRIES
ISO 9001:2000 CERTIFIED

Taber[®] Abraser Wheel Resurfacing

Resurface Taber abrading wheels with precision.

The Model 250 Wheel Refacer is recommended to refresh the contact surfaces of Calibrade[®] wheels. This instrument can also be used to true out of round wheels and correct 'crowning' conditions on both Calibrase[®] and Calibrade[®] wheels.

Rugged design is built to last.

The refacing diamond is mounted in an adjustable diamond tool holder, which is supported on a shielded traverse slide. Abrading wheels are mounted on a flanged extension of the motor shaft. A durable, cast housing provides ample weight to prevent chatter during operation. Attaching the Taber Abraser vacuum unit hose to the rear receptacle draws off abrasive cuttings.

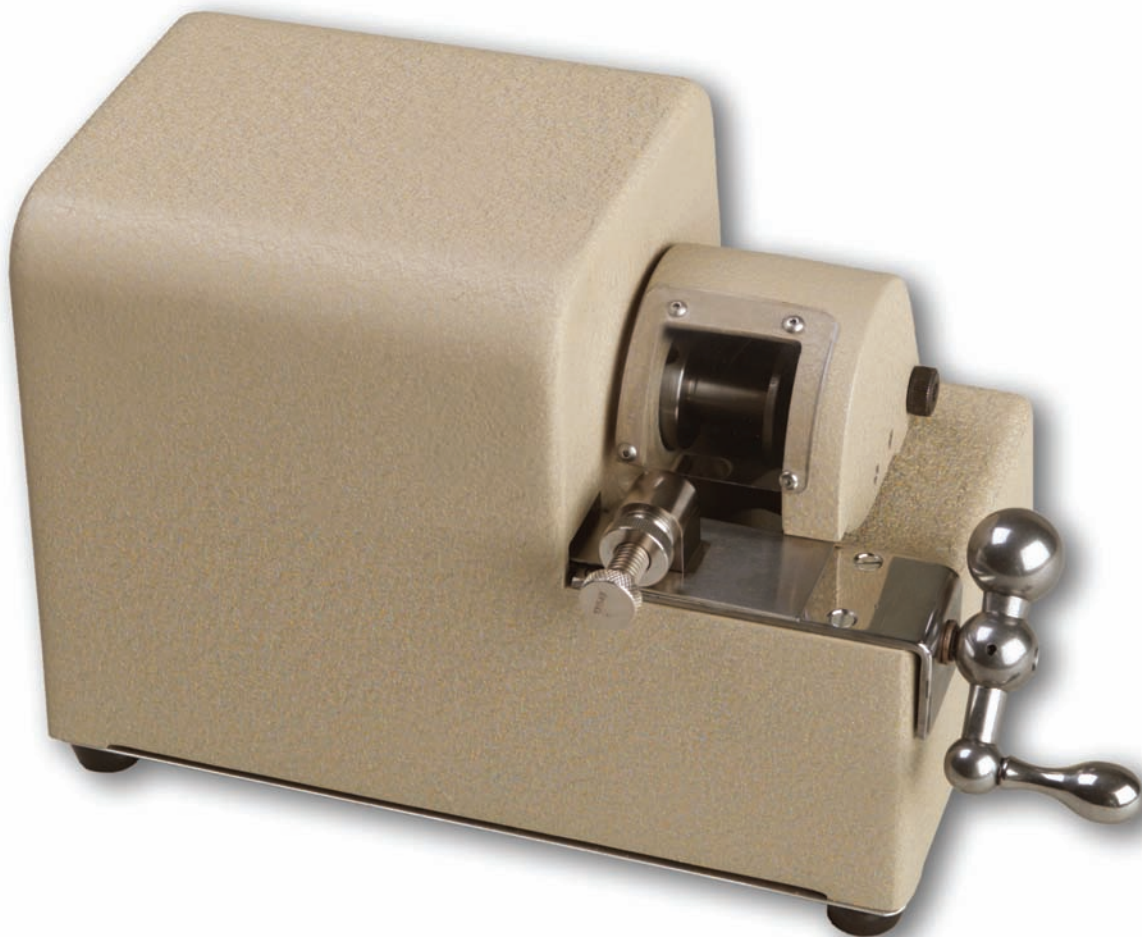

Wheel Refacer 250

Taber® Abraser Wheel Resurfacing

Standard Features:

- Hinged wheel guard with safety off sensor
- Plugs into accessory receptacle on Taber Rotary Abraser
- Replaceable diamond tools
- Shielded traverse slide
- Feed screw crank

CE

Available Accessories:

- Single Point Diamond Tool
- Multiple Point Diamond Tool (use for H-38 wheels)

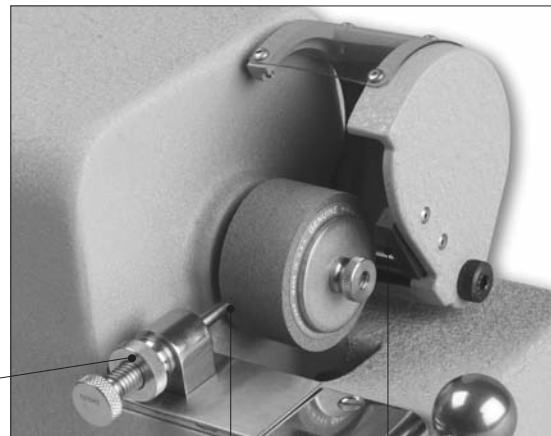

Lock Nut

Diamond Tool

Safety off Sensor

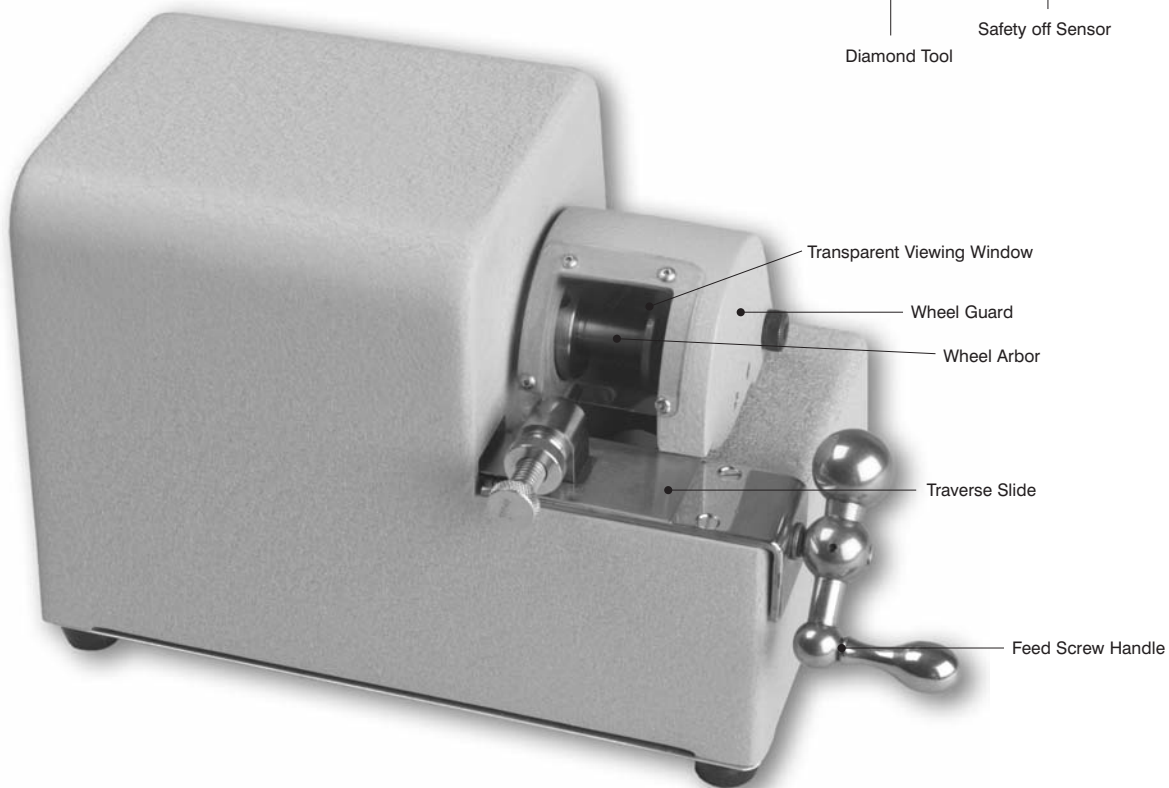

Transparent Viewing Window

Wheel Guard

Wheel Arbor

Traverse Slide

Feed Screw Handle

TABER
INDUSTRIES

Setting the Industry Standard

455 Bryant Street
North Tonawanda, New York 14120 USA

For more information:
Call 1.800.333.5300 (U.S.) or 716.694.4000 (outside U.S.)
Fax 716.694.1450
Email us at sales@taberindustries.com
Visit us at www.taberindustries.com